

Analysis of vitamin K in foods using HPLC with column-switching

Vitamin K is a fat-soluble vitamin. Vitamin K1 (phylloquinone) and vitamin K2 (menaquinones) are both naturally occurring, with vitamin K1 being abundant in green plants, and K2 abundant in cheese and fermented soybeans. K2 is menaquinone-n (MK-n); according to the number of isoprenes in its side chain. In general, MK-4 is abundant in fermented soybeans and MK-7 is abundant in fermented soybeans.

Vitamin K3 is an industrially synthesized compound that does not exist in nature.

Vitamin K was analyzed by solvent extraction and injection onto a solid-phase extraction-purified test solution into a column-switching HPLC system.

In the HPLC system, a switching valve is controlled to facilitate the concentration of target components and removal of contaminants.

Examples: Analysis of vitamin K

(K.Suzuki)

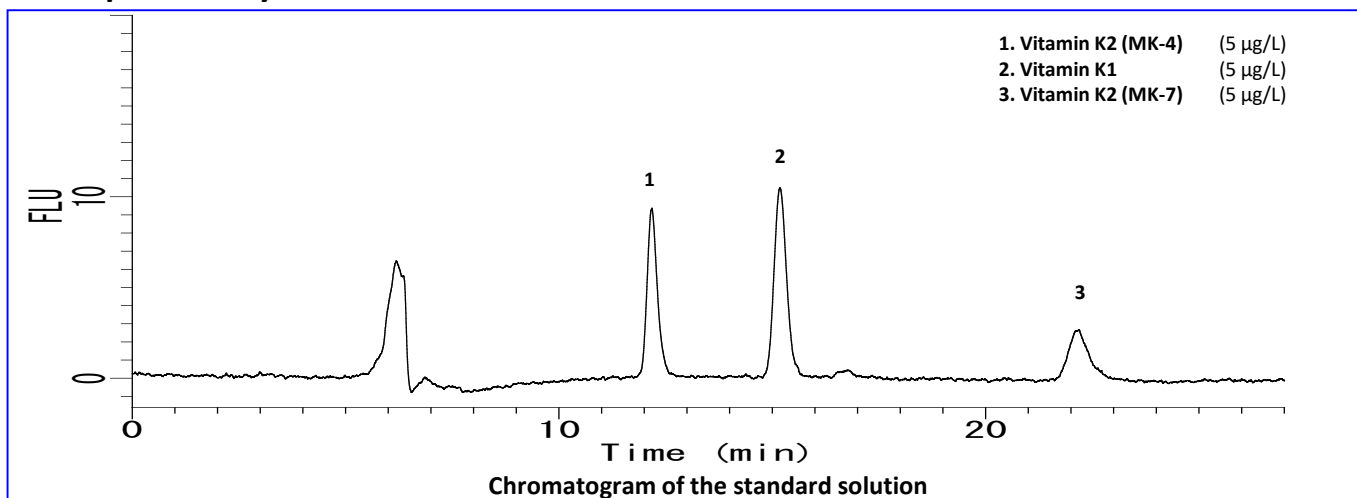

HPLC conditions

Precolumn	: Inertsil ODS-3 (5 µm, 50 x 4.6 mm I.D.)
Analytical column	: Inertsil ODS-3 (5 µm, 250 x 4.6 mm I.D.)
	Reduction column platinum black column
Eluent	: A) C ₂ H ₅ OH B) CH ₃ OH
(Pump A)	A/B = 5/95 v/v, 1 mL/min
Eluent	: A) C ₂ H ₅ OH B) CH ₃ OH
(Pump B)	A/B = 50/50 v/v, 1 mL/min
Temperature	: 40 °C
Detector	: FL Ex 320 nm Em 430 nm
Injection volum	: 50 µL

2.5 minutes after injection, the sample is introduced onto the analysis column from the precolumn

Return the valve 6 minutes after injection.

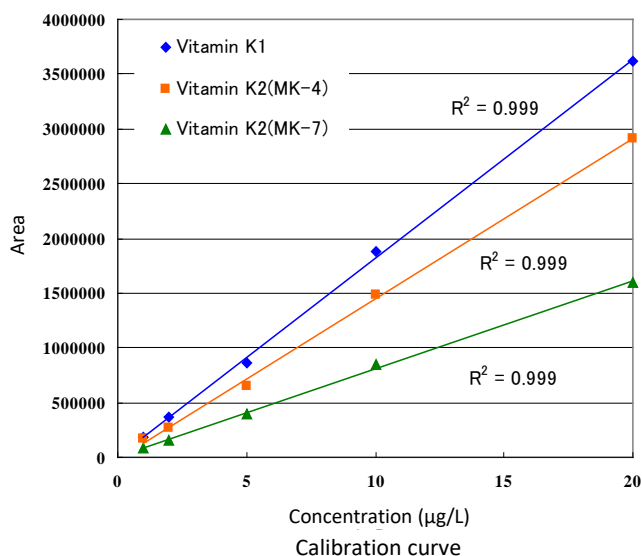

Structural formula

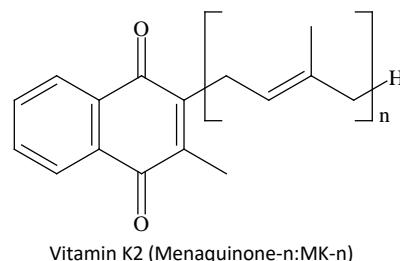
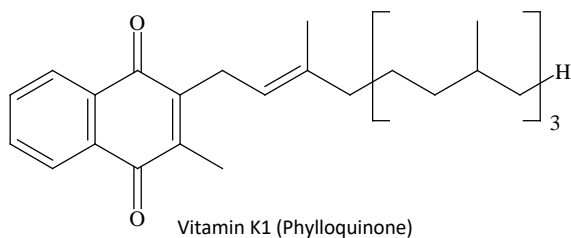

Structures are created using Chemistry 4-D Draw which is provided by ChemInnovation Software, Inc.

Column switching is frequently used to remove contaminants and to concentrate compounds. Manual pretreatment has the disadvantage of not controlling reproducibility, an automated column switching system is very effective because the timing is accurately controlled.

A diagram of the flow path of the column switching system is shown in the figure below, and the flow of sample injection is shown in the figure to the right. First, a sample injected by an autosampler is introduced onto a precolumn to remove contaminants and to concentrate the target components. Then, just before the target components are eluted from the pre-column, a six-way valve is switched and the pre-column is flushed with a solvent of different composition from the reverse direction. As a result, the target components retained on the precolumn are eluted and introduced onto the assay column. After the sample is introduced onto the analysis column, the valve switches again to wash and equilibrate the pre-column. This process enables sample concentration and removal of contaminants, allowing further separation of the target components on the analysis column.

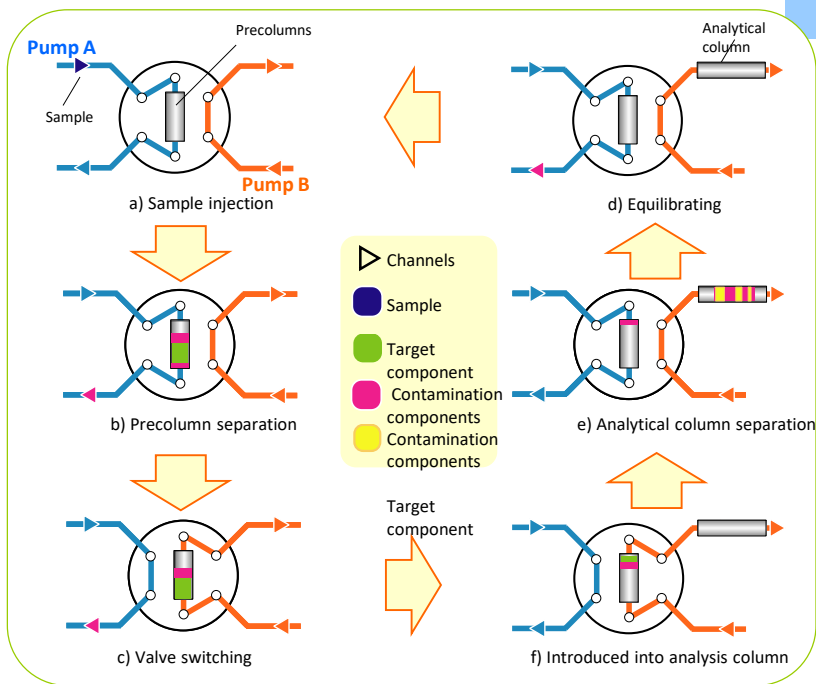

Analytical conditions and flow chart

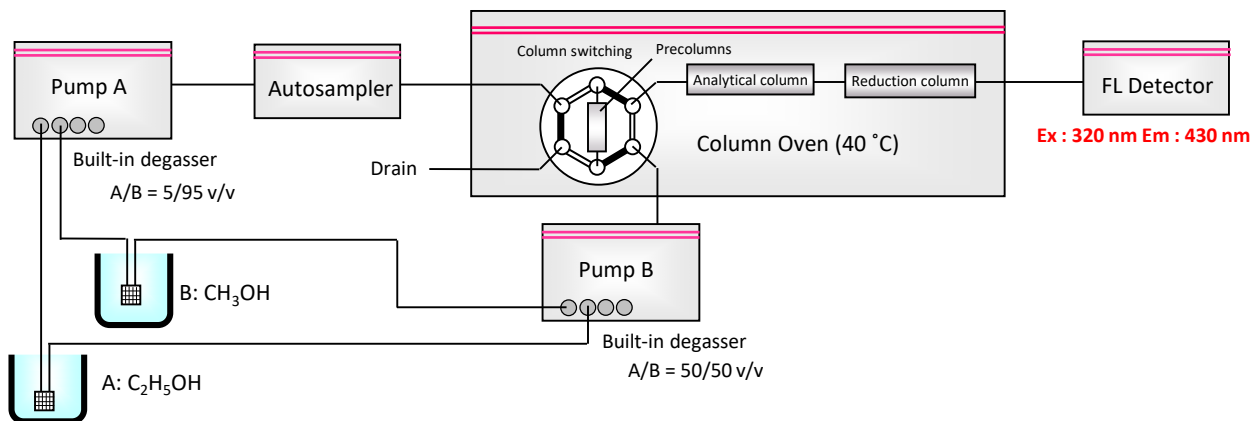

Fluorescence of Vitamin K using a Reduction Column

When vitamin K (quinone) is reduced to the hydroquinone, it becomes fluorescent.

Reduction can be made by contact with a catalyst such as platinum black or by using a reducing reagent. The latter method has the disadvantage of large reagent deactivation as well as the need for an additional pump.

In this paper, the former method was adopted, and platinum black was used in a packed column.

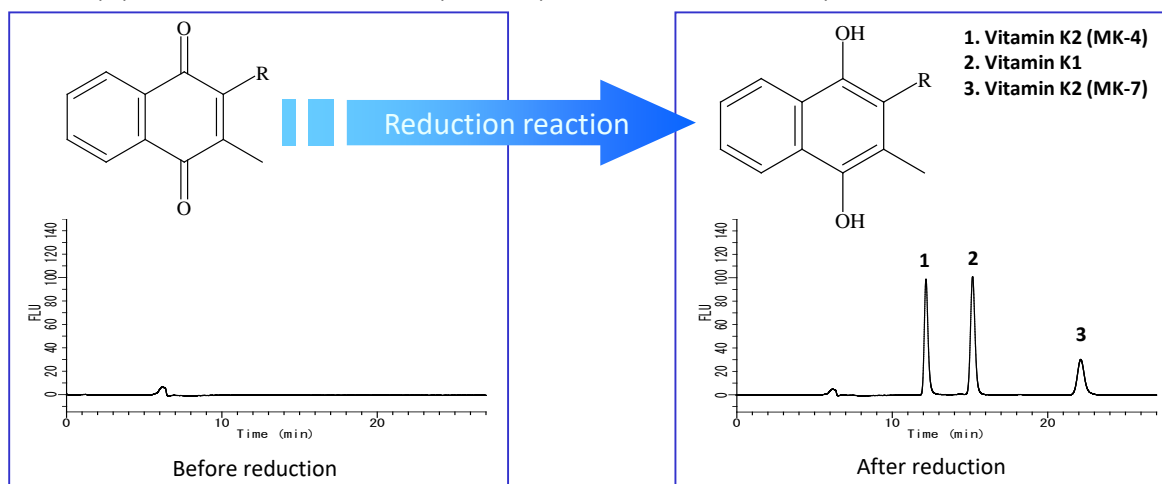

Examples: Vitamin K pretreatment in foods

Cereal and dry matter extractions

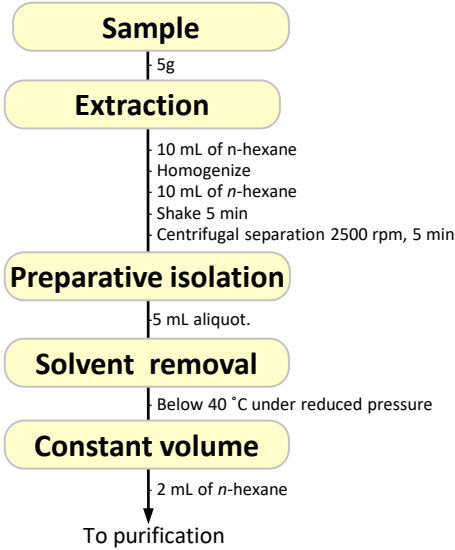

Extraction of fats and oils and fats

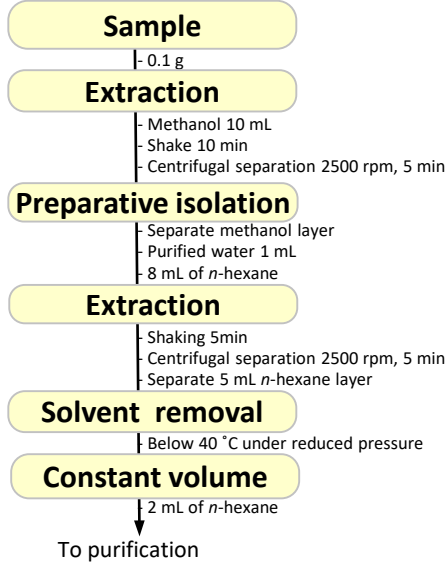

Extraction of other general foods

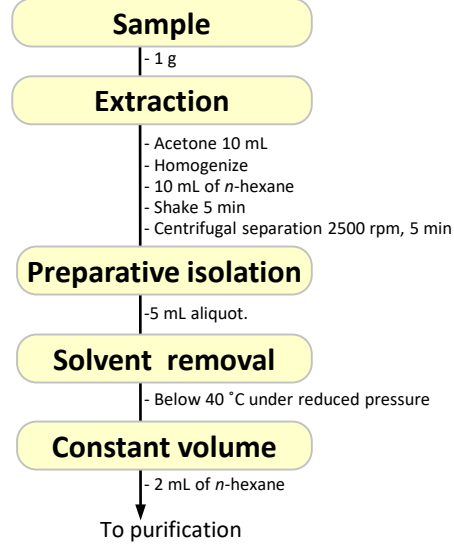

Purification operation

Mega BondElut
SI 1g / 6mL

Sample through

- Load sample

Washing

- 5 mL of *n*-hexane

Elution

- Mixture of diethyl ether and *n*-hexane
(4:96, v/v) 5mL

Solvent removal

- Below 40 °C under reduced pressure

Constant volume

If necessary, perform thin-layer chromatography
and further purify.
- Ethanol 200 µL

Column switching
HPLC-FL

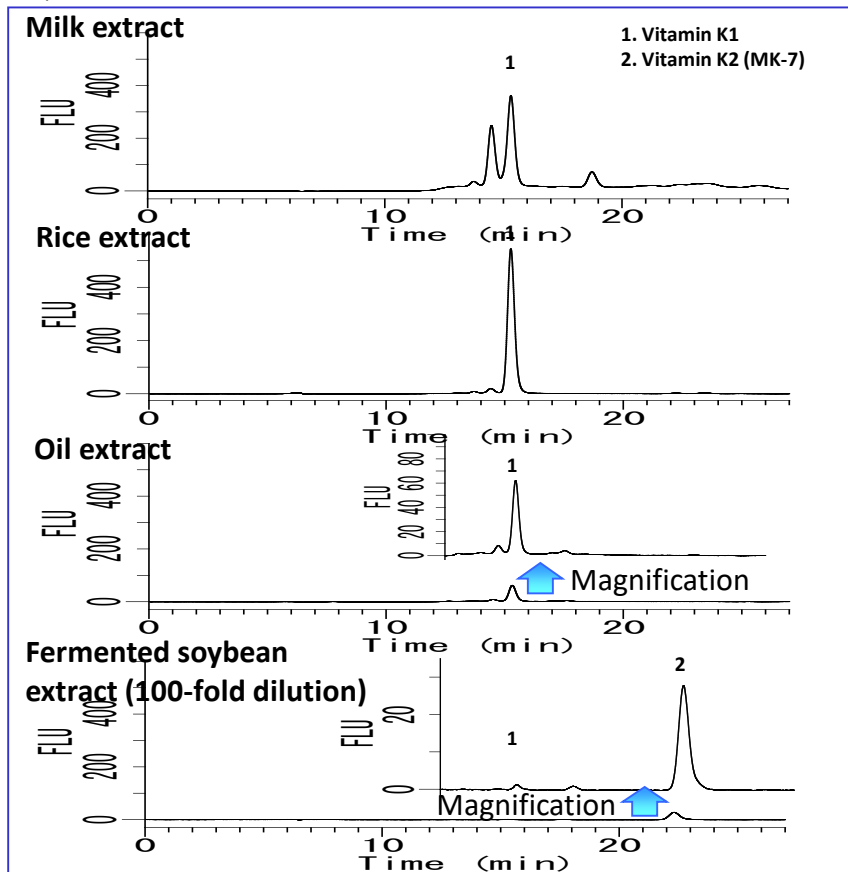

GL Sciences disclaims any and all responsibility for any injury or damage which may be caused by this data directly or indirectly. We reserve the right to amend this information or data at any time and without any prior announcement.

GL Sciences, Inc. Japan

22-1 Nishishinjuku 6-Chome
Shinjuku-ku, Tokyo,
163-1130, Japan
Phone: +81-3-5323-6620
Fax: +81-3-5323-6621
Email: world@glsc.co.jp
Web: www.glsciences.com

GL Sciences B.V.

De Sleutel 9
5652 AS Eindhoven
The Netherlands
Phone: +31 (0)40 254 95 31
Email: info@glsciences.eu
Web: www.glsciences.eu

GL Sciences (ShangHai) Ltd.

Tower B, Room 2003,
Far East International Plaza,
NO,317 Xianxia Road,
Changning District.
Shanghai, China P.C. 200032
Phone: +86 (0)21-6278-2272
Email: contact@glsciences.com.cn
Web: www.glsciences.com.cn

GL Sciences, Inc. USA

4733 Torrance Blvd. Suite 255
Torrance, CA 90503
Phone: 310-265-4424
Fax: 310-265-4425
Email: info@glsciencesinc.com
Web: www.glsciencesinc.com

International Distributors

Visit our Website at www.glsciences.com/distributors